



think office

#01_operativi_operational

MOBILofficefurniture



#01_operativi_operational

MOBILofficefurniture

INDICE | CONTENT | SOMMAIRE

05	mobil office furniture - company profile mobil office furniture - company profile mobil office furniture - company profile
14	scrivenie operative operational desks bureaux opérationnels
16	quadro
32	line
48	point2
64	t_cube
80	sketch2
96	krin
112	storage containers rangement
120	abaco degli elementi element abacus mélange des éléments
128	materiali e finiture materials and finishes matériaux et finitions



MOBILofficefurniture

Mobil Office Furniture, nata nel 1998, con uno stabilimento di 15.000 mq, fa parte della SCL&B Srl ed ha fatto del design e della funzionalità dell'arredo ufficio il proprio Core Business impostando la propria strategia di mercato nella ricerca continua di nuove soluzioni e finiture. Un'attenzione particolare è rivolta al rispetto per l'ambiente e all'ergonomia del posto di lavoro.

Mobil Office Furniture, born in 1998, with a factory of 15'000 mq, is part of SCL&B Srl. Its Core Business is made by design and functionality of office furniture, setting up their own market strategy, always searching new solution and finishes. A particular attention is directed towards the respect for the environment and the ergonomic of the work place.

Mobil Office Furniture, née en 1998, avec un établissement de 15'000 mq, est à partie du SCL&B Srl et a fait du design et du fonctionnalité des fournitures de bureau son Core Business en imposant sa stratégie commerciale dans la recherche de nouveaux solution et finition. Un attention particulière est adressée au respect pour l'environnement et au ergonomie du poste de travail.

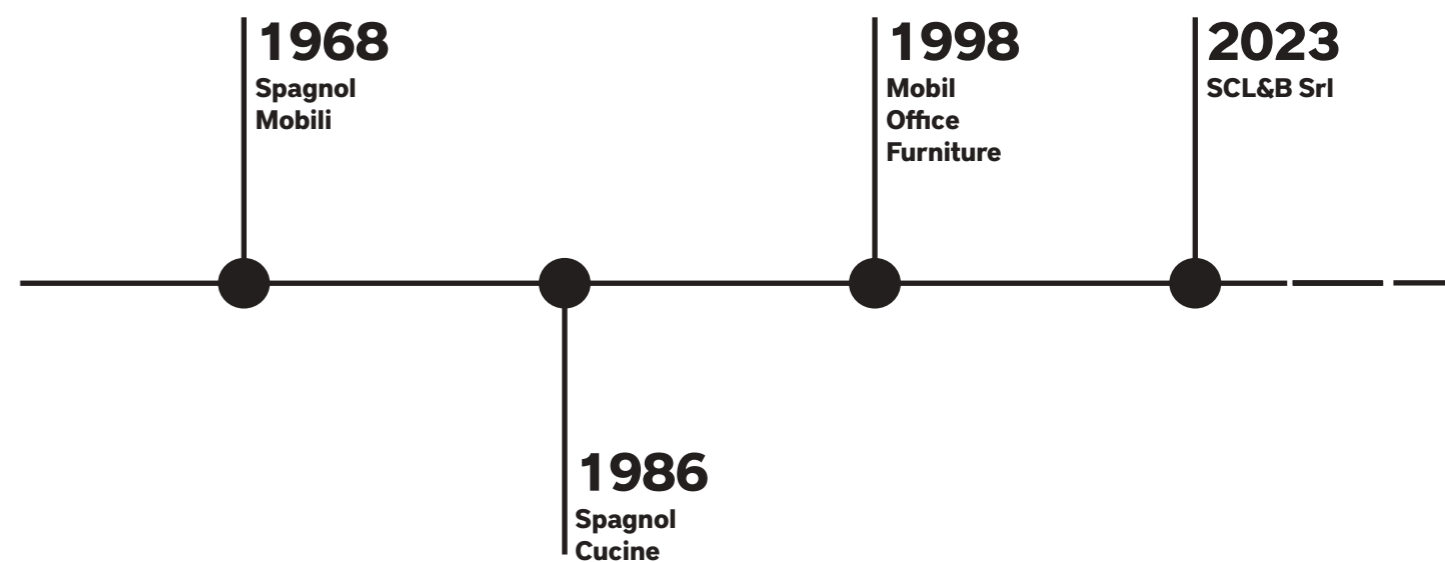

mission



Mobil Office Furniture è specializzata nella produzione di sistemi d'arredi sia uffici direzionali che operativi, produce e realizza sistemi di divisione degli spazi e fornisce progetti "chiavi in mano" sia ad enti privati che pubblici sia in Italia che all'estero. Le soluzioni d'arredo proposte sono orientate a migliorare la qualità dei luoghi di lavoro, con molta attenzione al rispetto dei regolamenti vigenti in termini di sicurezza e comfort. Le molteplici finiture e colori disponibili nelle varie collezioni permettono di rendere l'ambiente di lavoro piacevole e dinamico.

Mobil Office Furniture is specialized on the production of furnishing systems both directional and operational offices, produce and realize division space systems and provides "turn-key" projects to both private and public institutions in Italy and abroad. The furnishing solutions proposed are oriented to improve the quality of the work places, with lot of attention towards the respect for security regulations and comfort. The various finishing and colors available on the different collections allow the work place to be pleasant and dynamic.

Mobil Office Furniture est spécialisée dans la production de système de fournitures soit de bureau directionnelles que opérationnelles, il produit et réalise systèmes de séparation d'espace et donne des projet "clés en main" soit aux établissements privé que public, en Italie et à l'étranger. Les solutions des fournitures proposée sont orientée à améliorer la qualité du poste de travail, avec beaucoup d'attention au respect des réglementation de sécurité et de confort. les nombreuses finitions et couleurs disponibles dans les différents collections permettent de rendre le poste de travail plaisante et dynamique.



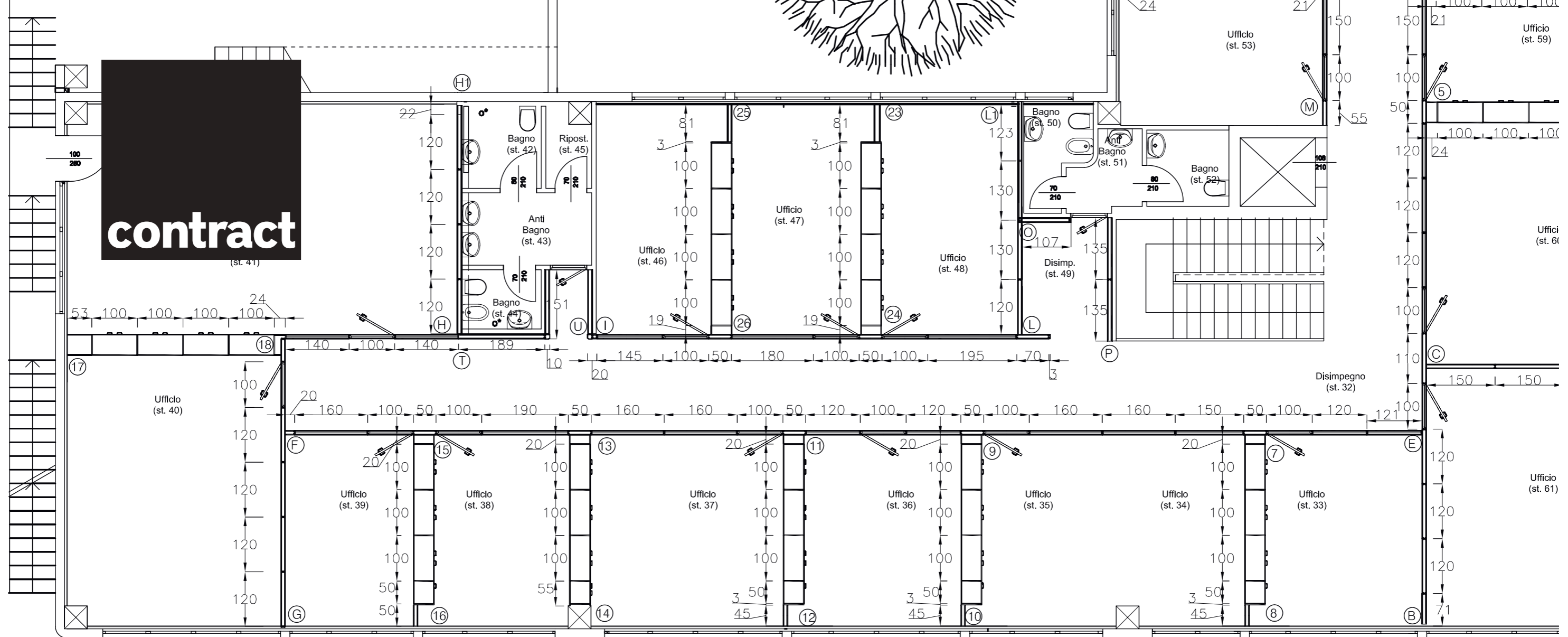

Forte di una lunga e collaudata esperienza nella produzione di arredi per la casa, da anni opera anche nel settore CONTRACT sia in Italia che all'estero con notevole esperienza tecnica nella progettazione, nella produzione e nella personalizzazione di arredi per uffici, aziende, hotel.

Strong of a long and tested experience on the production of furniture for the house, for years works even in the CONTRACT sector in Italy and abroad with remarkable technical experience in the design, production and personalization of furniture for offices, companies, hotels.

Fort d'une long et testée expérience dans la production des fournitures pour la maison, depuis des années il travail aussi dans le secteur CONTRACT soit en Italie que à l'étranger avec remarquable expérience technique dans le design, production et personnalisation des four-nitures de bureau, entreprises, hôtels.

- Consulting
- Customer care
- Project
- Logistic
- Installation
- After sales support

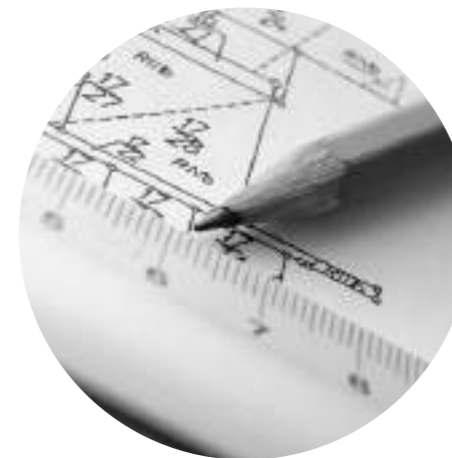

Customer support

Environment

10 **La nostra è una terra fortunata.
Ours is a very fortunate Region.
Notre région est une terre riche.**

La nostra è una terra fortunata. Qui sono nati celebri architetti e capaci artigiani, raffinati pittori e scultori, insigni musicisti e compositori. In ogni luogo c'è una bellezza creata dall'abilità e dal genio dei nostri Antenati. Nel 2019 le nostre Colline del Prosecco di Conegliano e Valdobbiadene sono state dichiarate Patrimonio dell'Umanità UNESCO. La ricerca del bello e dell'armonia è una nostra dote naturale.

Our is a very prosperous Region. Here many famous architects and skilled artisans, fine artists and sculptors were born. Everywhere you go, you can find the beauty created by the skill and genius of our ancestors. In 2019 the Prosecco Hills of Conegliano and Valdobbiadene were declared a UNESCO World Heritage Site. The search for beauty and harmony is our natural.

Notre région est une terre riche. Architectes célèbres et artisans capables, peintres et sculpteurs raffinés sont nés ici. Dans chaque endroit, il y a une beauté créée par l'habileté et le génie de nos ancêtres. En 2019, les collines du Prosecco de Conegliano et Valdobbiadene ont été déclarées site du patrimoine mondial de l'UNESCO. La recherche de la beauté et de l'harmonie est une qualité naturelle pour nous.



100% Made in Italy



Concept- Design- Made 100% in Italy
Ogni prodotto è progettato, concepito e realizzato totalmente in Italia per assicurare un elevato standard qualitativo.

Design and concept 100% made in Italy

Every product is designed and realized completely in Italy to ensure a high quality standard, with a unique technological know-how, pursuing a handcrafted ability combined with highly flexible and adaptable structures.

Design et concept 100% made in Italy

Chaque produit est projeté, conçu et réalisée totalement en Italie pour assurer un élevé standard qualitatif, avec un know-how technologique unique, en poursuivant une capacité artisanale combinée aux équipements hautement flexibles et polyvalentes.

Standard qualitativi d'eccellenza.
Aderire ai più alti standard qualitativi internazionali, garantisce prodotti progettati secondo i migliori criteri di funzionalità, ergonomia e design, consegne sicure e rapide e montaggi efficienti.

Excellence quality standard

Joining the highest International quality standard shall ensure products designed by the best functionality, ergonomics parameters; safe and fast deliveries and efficient assembly.

Standard qualitatifs d'excellence

Adhérer au plus élevés standard qualitatifs internationaux, assure produits conçus selon les meilleurs critères de fonctionnalité, ergonomie et design, livraison sûres et rapides et assemblages efficientes.

Ecologia e ambiente

Cosa significa eco-sostenibile? Sentiamo spesso parlare di eco-sostenibilità, ma in molti, hanno un'idea ancora molto vaga di cosa significa eco-sostenibile nello specifico. Eco-sostenibile o eco-friendly, consiste in una serie di comportamenti compatibili con l'ambiente circostante in quanto non ne usurpano le risorse. Chi sceglie di aiutare l'ambiente e quindi di essere eco-sostenibile, grazie ad una serie di piccole azioni giornaliere come ad esempio, ridurre gli sprechi, riciclare e riutilizzare, si contribuisce alla salvaguardia del pianeta riducendo l'accumularsi rifiuti nell'indifferenziato.

What does environmentally sustainable mean? We often hear talks about environmentally sustainable, but lots of people still do not have a clear idea about what environmentally sustainable means. Environmentally sustainable or eco-friendly, consist of a series of behaviors compatibles with the surrounding environment since they shall not encroach the resources. People who choose to help the environment and so to be environmentally sustainable, thank to a series of little daily actions like, cut down on waste, recycling and reuse, contributes to protection of the Earth reducing accumulation of mixed waste.

Qu'est-ce que cela signifie écologique? Nous entendons souvent parler d'écologique, mais dans de nombreux, ont un' idée vague de ce qu'est écologique. Écologique ou eco-friendly, consiste en une série de comportement compatibles avec l'environnement en tant que n'empiètent pas les ressources. Qui choisit d'aider l'environnement et ensuite d'être écologique, grâce à une série de petites actions journalières comme par exemple, réduire les gaspillages, recycler et réutiliser, on contribue à la sauvegarde de la Terre en réduisant l'accumuler des déchets mixtes.



ISO 9001
ISO 14001





scrivanie operative

Mettiamo al centro “l’essere umano” e il suo benessere, stimolando i suoi sensi in un’esperienza di operatività e funzionalità. Trasformiamo l’ufficio in un’esperienza straordinaria attraverso la costante innovazione di forme e materiali che aiutano a rendere il lavoro sinergico tra gli strumenti utilizzati e la continua evoluzione dell’automazione. Rispondiamo alle necessità del buon lavoro nel rispetto di chi lavora.

We focus on “the human being” and his well-being, stimulating his senses in an experience of operation and functionality. We turn the office into an extraordinary experience through the constant innovation of shapes and materials that help to make the work synergistic between the tools used and the continuous evolution of automation. We respond to the needs of good work in respect of those who work.

Nous mettons au centre « l’être humain » et son bien-être, en stimulant ses sens dans une expérience de fonctionnement et de fonctionnalité. Transformons le bureau en une expérience extraordinaire grâce à l’innovation constante de formes et de matériaux, qui aident à rendre le travail synergique entre les outils utilisés et l’évolution continue de l’automatisation. Nous répondons aux besoins du bon travail dans le respect des personnes qui travaillent.

- **quadro**
- **line**
- **point2**
- **t_cube**
- **sketch2**
- **krin**

quadro

**Elegante sobrietà, vivace multifunzionalità.
Grazie alla sua struttura minimale, la
scrivania Quadro, si adatta alle funzioni e
allo stile di ogni ambiente.
I piani lavoro permettono di ricreare da
postazioni singole e semplici a soluzioni
multipiano/workstations condivise per
operatività di gruppo e riunione.**

Elegant sobriety, lively multifunctionality.
Thanks to its minimal structure, the Quadro desk,
adapts to the functions and style of any environment.
Countertops allow to recreate from single and simple
workstations with shared multideck/workstation solutions for
group and meeting operations.

Sobriété élégante, multifonctionnalité vivante.
Grâce à sa structure minimale, le bureau Quadro
s'adapte aux fonctions et au style de chaque environnement.
Les plans de travail permettent de recréer des postes de travail
simples à des solutions multipièces/stations de travail partagées pour
les opérations de groupe et de réunion.

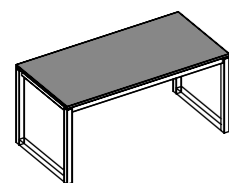

quadro

metallo | metal | metal

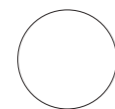

bianco
white
blanc



antracite
anthracite
anthracite



colori RAL
RAL colours
Couleurs RAL



17

quadro

MOBILofficefurniture

16







**Lo spazio operativo si dilata
senza rinunciare all'estetica.
Documenti, materiali e carte
sempre in ordine grazie agli
elementi integrati al sistema.**

The operating space expands without sacrificing aesthetics. Documents, materials and papers always in order thanks to the integrated elements of the system.

L'espace de travail se dilate sans renoncer à l'esthétique. Des documents, matériaux et cartes toujours en ordre grâce aux éléments intégrés au système.







Dall'operativo al semidirezionale, con uno stile elegante e finiture appropriate. Quadro permette di creare postazioni di fascia più alta con grande coerenza estetica e funzionale.

From operational to semi-directional, with an elegant style and appropriate finishes. Quadro allows you to create workstations of Higher quality with great aesthetic and functional consistency.

De l'opérationnel au semi-directionnel, avec un style élégant et des finitions appropriées. Quadro permet de créer des postes de travail plus haut de gamme avec une grande cohérence esthétique et fonctionnelle.







Postazioni singole o multiple; la fruibilità del piano lavoro è ottimizzata dall'utilizzo di accessori e contenitori che aiutano a lavorare in comodità, personalizzare lo spazio e risolvere ogni necessità operativa.

Single or multiple workstations; the usability of the worktop is optimized by using accessories and containers that help to work in comfort, customize the space and solve every operational need.

Des postes de travail simples ou multiples ; l'utilisation du plan de travail est optimisée par l'utilisation d'accessoires et de conteneurs qui aident à travailler dans le confort, à personnaliser l'espace et à résoudre tous les besoins opérationnels.



line

32

**Tavolo Line: ergonomia essenziale,
eleganza eterna.
Un sistema modulare per vivere qualsiasi
soluzione nell'ambiente di lavoro con
l'atmosfera e il calore di casa.**

Line table: essential ergonomics,
eternal elegance.
A modular system for living any solution in the workplace with
the atmosphere and warmth of home.

Table Line: ergonomie essentielle,
élégance éternelle.
Un système modulaire pour vivre n'importe quelle solution dans l'environnement de travail
avec l'atmosphère et la chaleur de la maison.

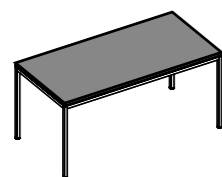

line

metallo | metal | metal

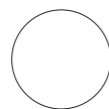

bianco
white
blanc



antracite
anthracite
anthracite



colori RAL
RAL colours
Couleurs RAL



33

line

MOBILofficefurniture





Line è un sistema arredo flessibile con spiccate caratteristiche di trasformazione; risponde a soluzioni operative e direzionale fino all'home office con la possibilità di adattarsi alle esigenze del lavoro singolo o di gruppo.

Line is a flexible furnishing system with strong characteristics of transformation; responds to operational and directional solutions up to the home office with the possibility of adapt itself to individual work or group.

Line est un système d'ameublement flexible avec des caractéristiques de transformation marquantes; il répond aux solutions opérationnelles et directionnelles jusqu'au bureau à domicile avec la possibilité de s'adapter aux besoins du travail individuel ou de groupe.





Tavoli riunione o grandi composizioni e piani bench per lavoro di gruppo sono esigenze sempre più richieste, sia negli ambienti direzionali che operativi.

Meeting tables or large compositions and bench plans for teamwork are increasingly in demand, both in directional and operational environments.

Les tables de réunion ou grandes compositions et les plans bench pour le travail de groupe sont des besoins de plus en plus demandés, tant dans les environnements directionnels qu'opérationnels.





Un ambiente dal sapore domestico nel contesto lavorativo attuale, iperconnesso e smart.

An environment with a domestic flavour in the actual work context, hyperconnected and smart.

Un environnement au style domestique dans le contexte professionnel actuel, hyperconnecté et intelligent.





Semplici concetti: elementi aggregabili creano composizioni base di forte rigore funzionale. In primo piano alcuni tra i dettagli salienti della scrivania e dei suoi accessori, che evidenziano la grande freschezza compositiva dei diversi componenti per risolvere ogni necessità operativa.

Simple concepts: aggregatable elements create basic compositions of strong functional rigor. In the foreground some desk highlights and its accessories, which emphasize the great compositional freshness of the different components to solve every operational need.

Des concepts simples : des éléments agréables créent des compositions de base d'une grande rigueur fonctionnelle. Au premier plan, certains des détails saillants du bureau et de ses accessoires, qui soulignent la grande fraîcheur de composition des différents composants pour résoudre tous les besoins opérationnels.



point2

48

**Sistema modulare flessibile ed elegante.
Nasce dall'evoluzione di un progetto
vincente e ricerca la massima funzionalità
con particolare attenzione all'estetica per
soddisfare le più svariate esigenze e
agevolare chi lavora.**

Flexible and elegant modular system.
Born from the evolution of a winning project
and research maximum functionality with particular attention to aesthetics to meet the most
varied needs and facilitate those who work.

Système modulaire flexible et élégant.
Il naît de l'évolution d'un projet
gagnant et recherche la fonctionnalité maximale avec une attention particulière à l'esthétique
pour répondre aux besoins les plus variés et
faciliter les personnes qui travaillent.

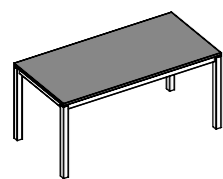

point2

metallo | metal | metal

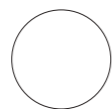

bianco
white
blanc



antracite
anthracite
anthracite



colori RAL
RAL colours
Couleurs RAL



49

point2

MOBILofficefurniture





**La varietà degli accessori
permette di attrezzare e
personalizzare il posto lavoro
alle esigenze di ogni
singolo operatore.**

The variety of accessories allows you to equip and personalize the workplace to the needs of each single operator.

La variété des accessoires permet d'équiper et de personnaliser le lieu de travail aux besoins de chaque opérateur individuel.





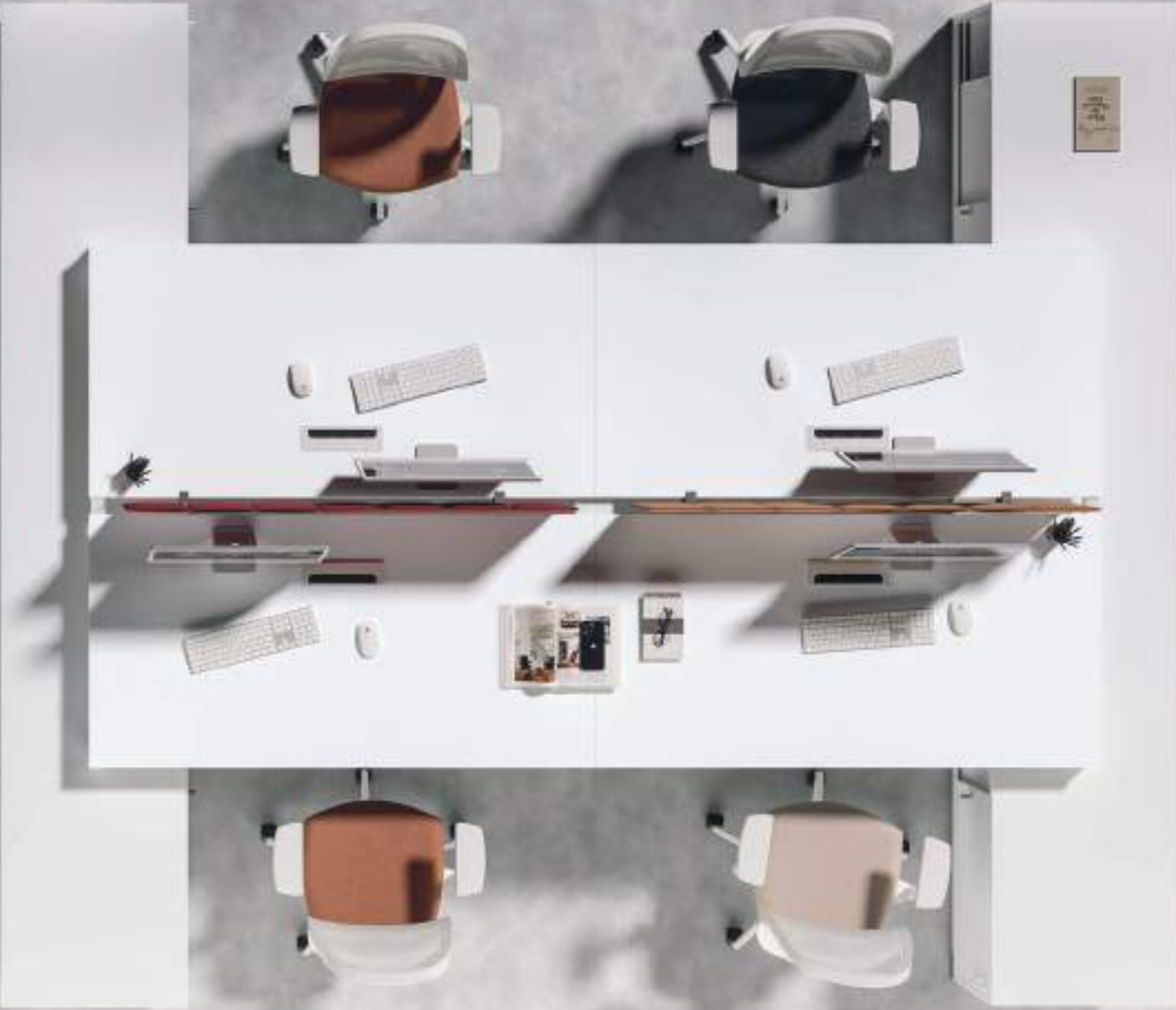





In primo piano alcuni tra gli accessori di servizio alla postazione di lavoro e al frontal pannel. Completano la proposta cassettiere su ruote, schedari, cassettiere portanti e l'elemento adattatore, che collega la base al piano lavoro.

In the foreground some of the service accessories to the workstation and the front panel. Complete the proposal chests of drawers on wheels, file cabinets, chest of drawers and the adapter element, that connects the base to the worktop.

Au premier plan, certains des accessoires de service au poste de travail et au panneau avant. Ils complètent la proposition de tiroirs sur roues, classeurs, tiroirs porteurs et l'élément adaptateur, qui relie la base au plan de travail.



t_cube

64

**Elogio della razionalità.
Scrivania t_cube: il suo sistema modulare
permette di realizzare molteplici
composizioni e di razionalizzare gli spazi,
a seconda delle esigenze.**

Praise of the rational.
t_cube desk: Its modular system allows you to create multiple
compositions and rationalize spaces, according to the requirements.

Éloge de la rationalité.
Bureau t_cube : son système modulaire permet de réaliser plusieurs
compositions et de rationaliser les espaces,
selon les besoins.

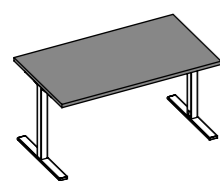

t_cube

metallo | metal | metal

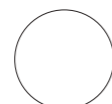

bianco
white
blanc



antracite
anthracite
anthracite



colori RAL
RAL colours
Couleurs RAL



65

t_cube

MOBILofficefurniture











t_cube ad altezza variabile. Le finiture, le composizioni e le altezze sono elementi che facilitano l'ergonomia del posto lavoro, combinabili con facilità grazie ad un'ampia proposta di materiali e soluzioni per creare uno spazio su misura e personalizzato.

t_cube with variable height. The finishes, compositions and heights are elements that facilitate the ergonomics of the workplace, easy to combine thanks to a wide range of materials and solutions to create a customized and personalized space.

t_cube à hauteur variable. Les finitions, les compositions et les hauteurs sont des éléments qui facilitent l'ergonomie du lieu de travail, facilement combinables grâce à une large proposition de matériaux et de solutions pour créer un espace sur mesure et personnalisé.

La struttura variabile si adatta alle funzioni e allo stile di ogni ambiente. Particolare attenzione è stata dedicata al cablaggio delle postazioni.

The variable structure is suitable for functions and style of any environment. Particular attention is been dedicated to wiring of workstations.

La structure variable s'adapte aux fonctions et au style de chaque environnement. Une attention particulière est dédiée au câblage des postes.







Semplicemente ergonomico. t_cube porta il piano scrivania all'altezza voluta. Con la semplice pressione di un tasto si ottiene in modo facile e veloce l'altezza desiderata del piano lavoro. Contenimento, componenti e relativi accessori sono pienamente integrati per offrire la massima utilizzazione dello spazio.

Simply ergonomic. t_cube brings the desk top to the desired height. By touching a button, the desired height of the worktop is quickly and easily achieved. Containment, components and accessories are fully integrated to offer maximum space utilization.

Simplement ergonomique. t_cube amène le plateau de bureau à la hauteur souhaitée. La simple pression d'une touche permet d'obtenir facilement et rapidement la hauteur souhaitée du plan de travail. Le confinement, les composants et les accessoires connexes sont entièrement intégrés pour offrir une utilisation maximale de l'espace.



sketch2

Operatività totale e utilizzo razionale delle varie soluzioni, dalla scrivania singola alle grandi composizioni lineari. L'evoluzione di Sketch2 rivisitato nella struttura più leggera e lineare al passo con l'evoluzione dello spazio lavoro.

Total operation and rational use of the various solutions, from single desk to large linear compositions. The evolution of Sketch2 revisited in the lightest and most linear structure updated with the evolution of the workspace.

Le fonctionnement total et l'utilisation rationnelle des différentes solutions, du bureau simple aux grandes compositions linéaires. L'évolution de Sketch2, réinterprété dans la structure la plus légère et linéaire en phase avec l'évolution de l'espace de travail.

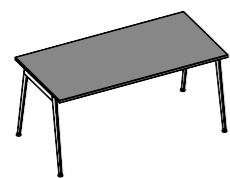

sketch2

metallo | metal | metal

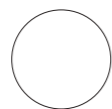

bianco
white
blanc



antracite
anthracite
anthracite



colori RAL
RAL colours
Couleurs RAL



81

sketch2

MOBILofficefurniture





Break Area

sketch2





Con questa collezione è possibile creare spazi operativi e riunione di alto valore estetico.

With this collection is possible to create operational and meeting spaces of high aesthetic value.

Avec cette collection, vous pouvez créer des espaces de travail et de réunion de grande valeur esthétique.



Sketch2, anche direzionale per una linea di arredo trasversale con finiture di pregio. Si definiscono gli spazi di lavoro con un nuovo concetto di cura del particolare e dell'accostamento dei colori.

Sketch2, also directional for a transversal furniture line with high quality finishes. Work spaces are defined with a new concept of attention to detail and colors combination

Sketch2, également directionnel pour une ligne d'ameublement transversal avec des finitions de qualité. Les espaces de travail sont définis par un nouveau concept de soin du détail et de la combinaison des couleurs.







Una struttura caratterizzata da una serie di elementi che permettono la realizzazione di composizioni infinite, con strutture che permettono di risolvere molteplici usi e configurazioni. L'uso degli elementi modulari e dei complementi offre una grande flessibilità di utilizzo e organizzazione dello spazio.

A structure characterized by a series of elements that allow the creation of endless compositions, with structures that allow to solve several uses and configurations. The use of modular elements and complements offers a great flexibility of use and organization of space.

Une structure caractérisée par une série d'éléments qui permettent la réalisation de compositions infinies, avec des structures qui permettent de résoudre de multiples utilisations et configurations. L'utilisation des éléments modulaires et des compléments offre une grande flexibilité d'utilisation et d'organisation de l'espace.

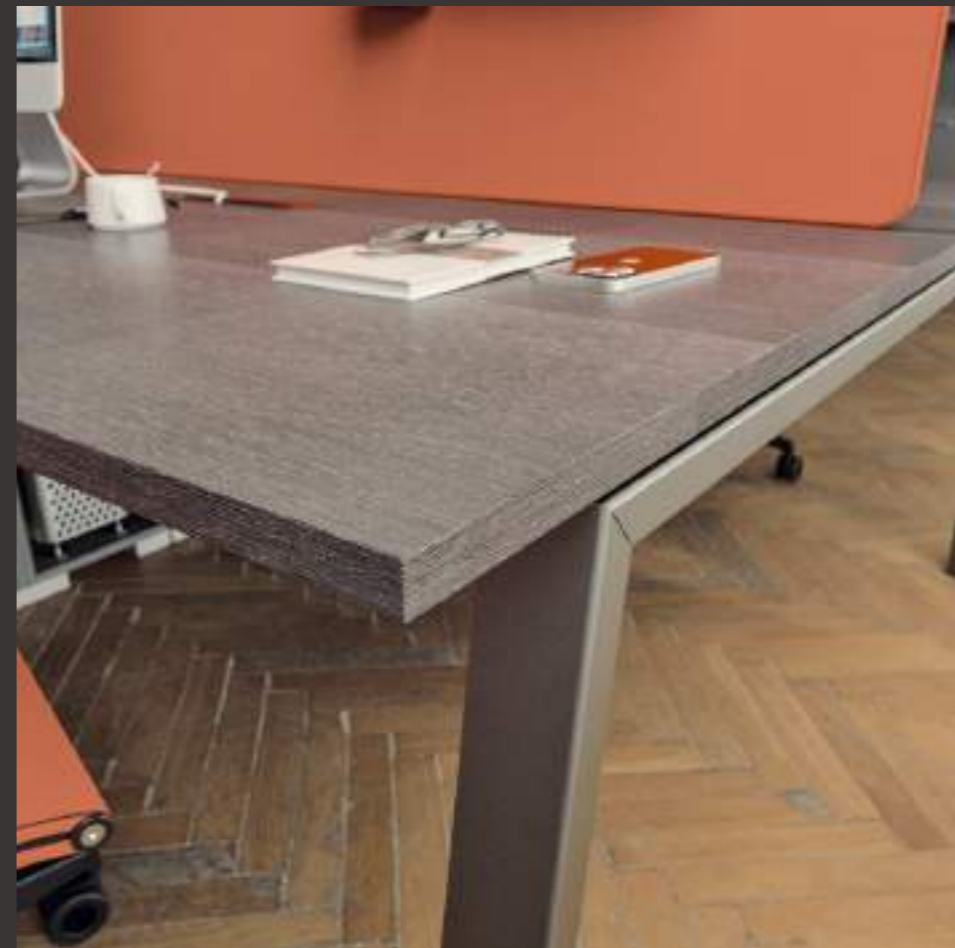

krin

96

**Classica e contemporanea.
Krin crea postazioni calibrate sulle
esigenze di chi lavora, definendo uno
spazio operativo personale e valorizzando
il suo utilizzo anche in spazi ridotti.**

Classical and contemporary.
Krin creates calibrated stations according to
those who work, defining a
personal operating space and enhancing
its use even in small spaces.

Classique et contemporain.
Krin crée des postes de travail adaptés aux
besoins de ceux qui travaillent, en définissant un
espace de travail personnel et en valorisant
son utilisation même dans des espaces réduits.

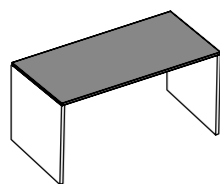

krin



97

krin

MOBILofficefurniture





Krin, pensata per creare ambienti dove stile e professionalità siano in sintonia con immagine e prestazioni.

Krin, designed to create environments where style and professionalism are in harmony with image and performance.

Krin, conçu pour créer des environnements où le style et le professionnalisme sont en harmonie avec l'image et les performances.





Krin, ideale per gli open space. Le scrivanie di questa collezione possono essere completate da divisori frontali che creano un'area personale.

Krin, ideal for the open space. The desks of this collection can be completed by dividers fronts that create a personal area.

Krin, idéal pour les espaces ouverts. Les bureaux de cette collection peuvent être complétés par des diviseurs avant qui créent un espace personnel.





Reception Krin. Elementi lineari e accostamenti di materiali, suggeriscono una ricerca di design per risolvere la necessità del ricevere.

Reception Krin. Items linear and combinations of materials, suggest a research of design for resolve the need for receive.

Réception Krin. Des éléments linéaires et des combinaisons de matériaux, suggèrent une recherche de design pour résoudre le besoin de recevoir.





Una vasta offerta di accessori, elementi di servizio, pensili a parete, cassetti, porta matite e porta carte aiuta a semplificare l'ordine nel lavoro. Pannellature, tipologie di contenimento e di cassettiere permettono infinite possibilità di archiviazione e composizione non solo estetiche, ma anche altamente funzionali.

A wide range of accessories, service elements, wall cabinets, drawers, pencil holders and card holders helps to simplify the order in the work. Panels, types of storage and drawers allow endless possibilities of storage and composition not only aesthetic, but also highly functional.



Une large gamme d'accessoires, d'éléments de service, de supports muraux, de tiroirs, de porte-crayons et de porte-cartes aide à simplifier l'ordre dans le travail. Les panneaux, les types de compartiments de rangement et les tiroirs permettent des possibilités infinies de rangement et de composition non seulement esthétiques, mais également très fonctionnelles.



storage

Contenitori Point, completano la gamma degli elementi di servizio al posto lavoro in diverse altezze e larghezze

Point containers, complete the range of service elements for the workplace in different heights and widths

Les compartiments de rangement Point complètent la gamme des éléments de service au poste de travail en différentes hauteurs et largeurs.

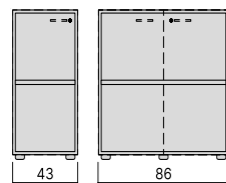

metallo | metal | metal

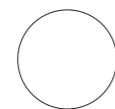

bianco
white
blanc



antracite
anthracite
anthracite

storage





**Contenere e archiviare con Halite.
Forme, tipologie , usi e capacità diversi
fanno del contenimento Halite un elemento
basilare per completare la gamma e le
richieste delle proposte ufficio.**

Contain and store with Halite. Shapes, types, uses and different capacities make Halite containment a basic element to complete the range and requests of office proposals.

Contenir et archiver avec Halite. Les différentes formes, types, utilisations et capacités font du compartiment de rangement Halite un élément fondamental pour compléter la gamme et les demandes des bureaux proposés.

116

117



storage

MOBIL officefurniture

Librerie in metallo o legno. Un gioco di pieni e di vuoti, elementi di arredo dalla forte personalità che completano l'arredo.

Metal or wood bookcases. A game of solid and voids, furniture elements with a strong personality that complete the furniture.

Bibliothèques en métal ou en bois. Un jeu de pleins et de vides, des éléments d'ameublement à forte personnalité qui complètent l'ameublement.



abaco

Abaco degli elementi

Element abacus

Mélange des éléments

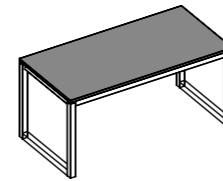

quadro

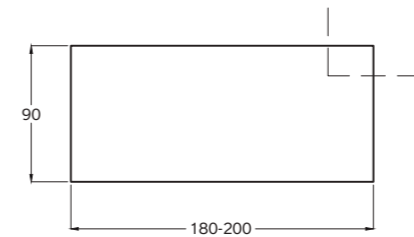
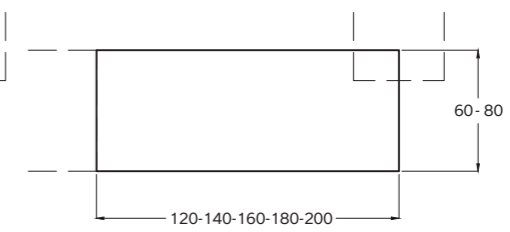
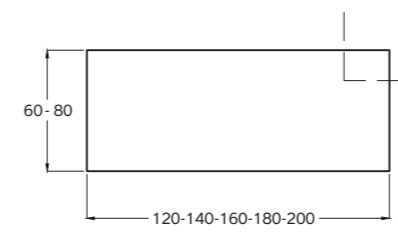
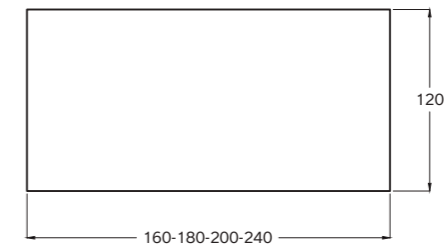
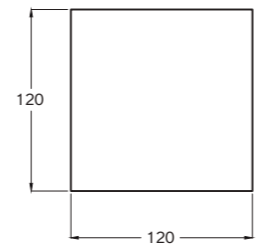
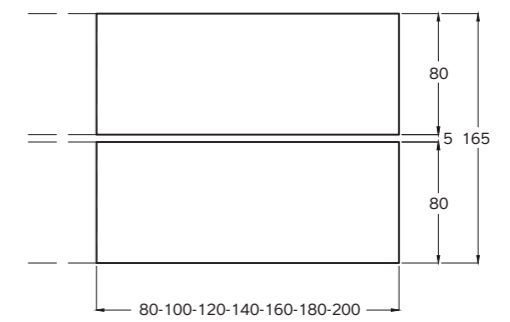
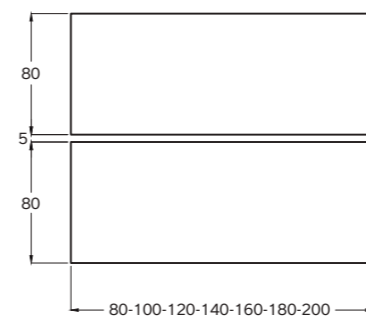
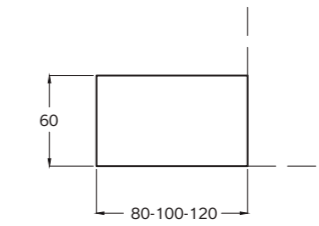
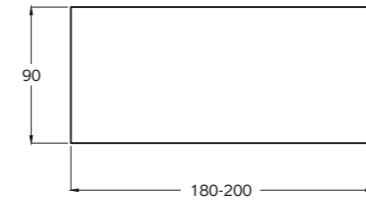
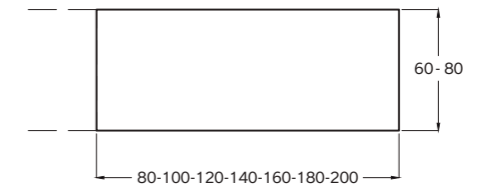
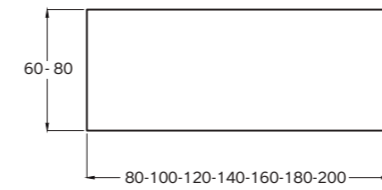

metallo | metal | metal

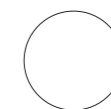

bianco
white
blanc



antracite
anthracite
anthracite



colori RAL
RAL colours
Couleurs RAL

quadro
line
point2
t_cube
sketch2
krin

line

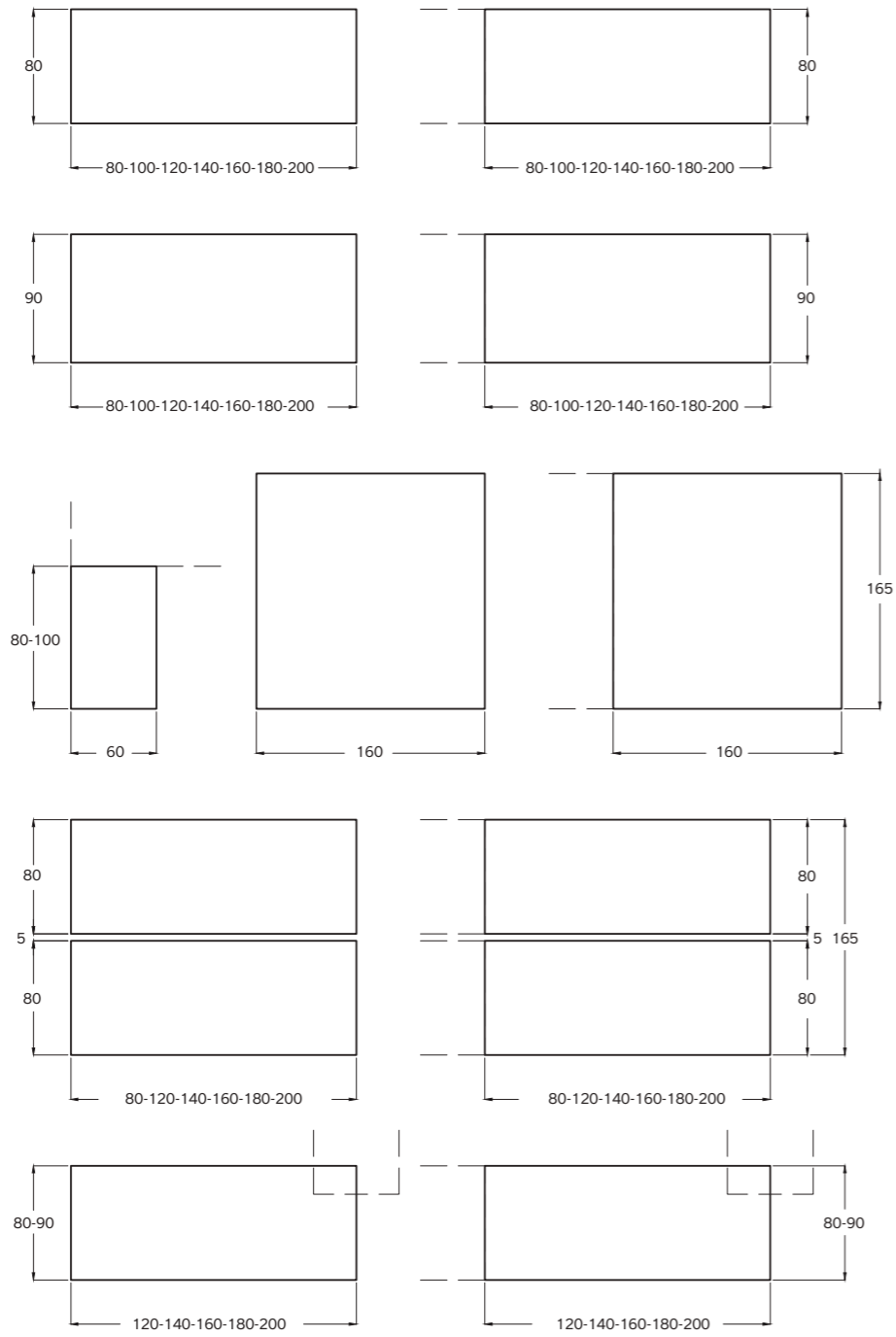
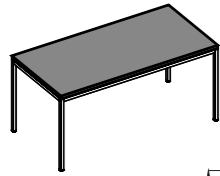

point2

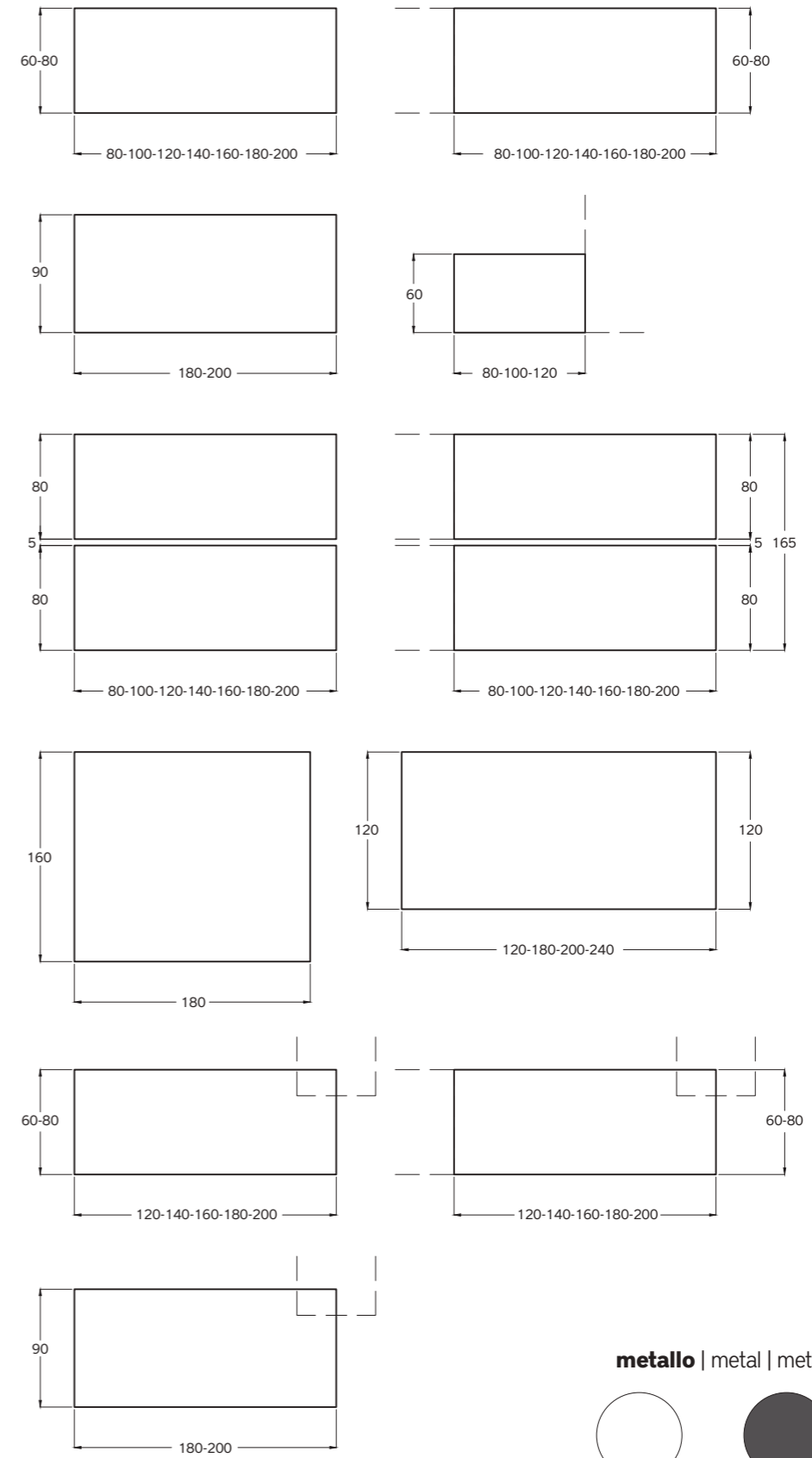
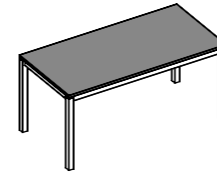

metallo | metal | metal

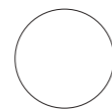

bianco
white
blanc



antracite
anthracite
anthracite



colori RAL
RAL colours
Couleurs RAL

metallo | metal | metal

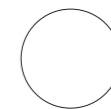

bianco
white
blanc



antracite
anthracite
anthracite



colori RAL
RAL colours
Couleurs RAL



t_cube

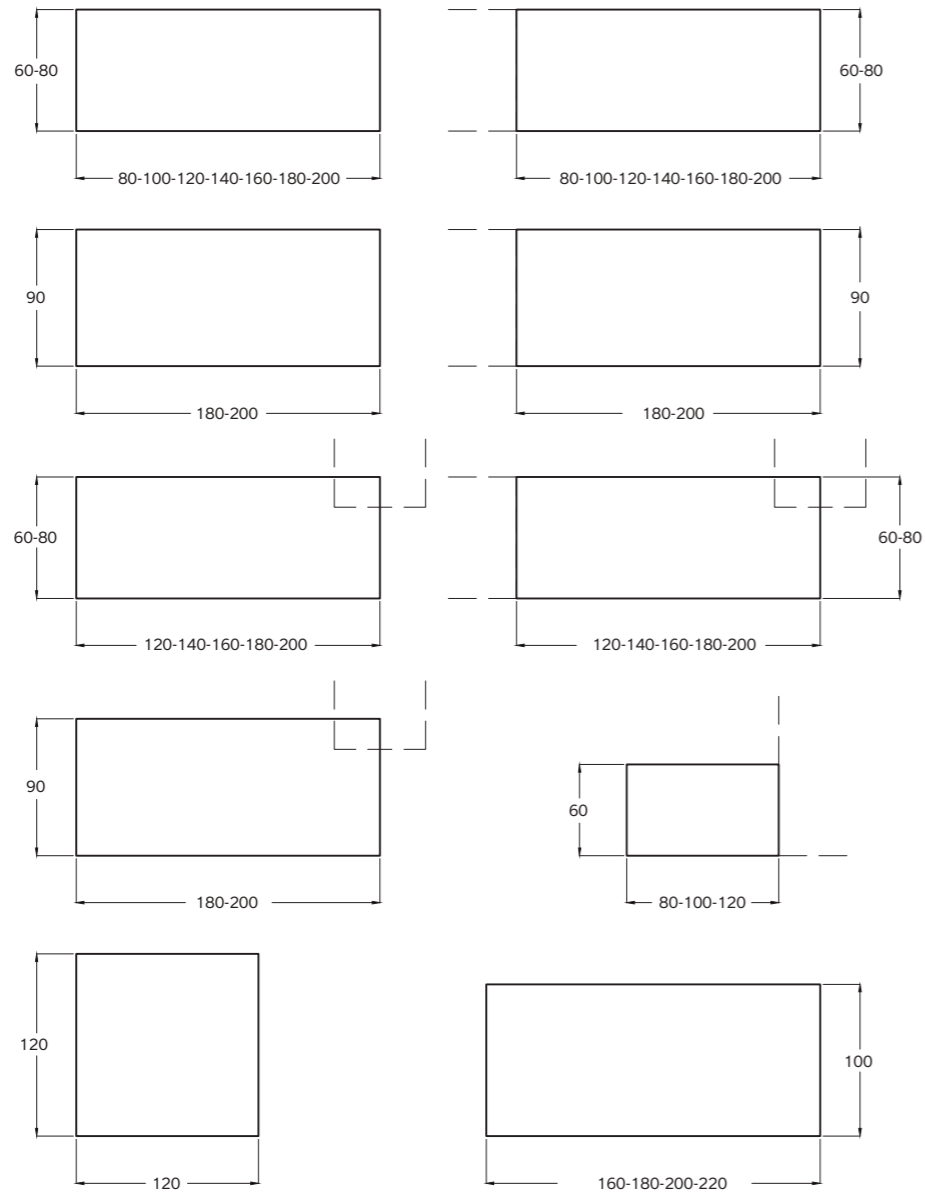
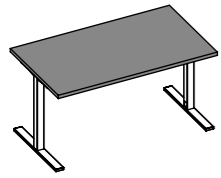

altezza regolabile elettricamente

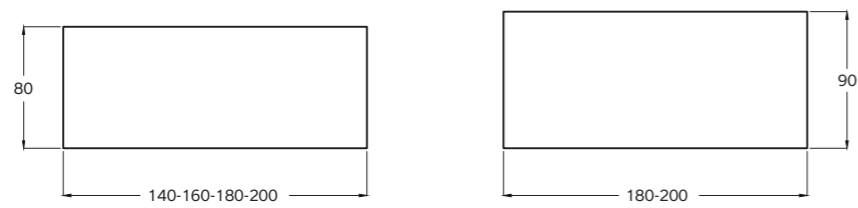

metallo | metal | metal

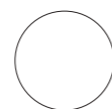

bianco
white
blanc



antracite
anthracite
anthracite



colori RAL
RAL colours
Couleurs RAL

sketch2

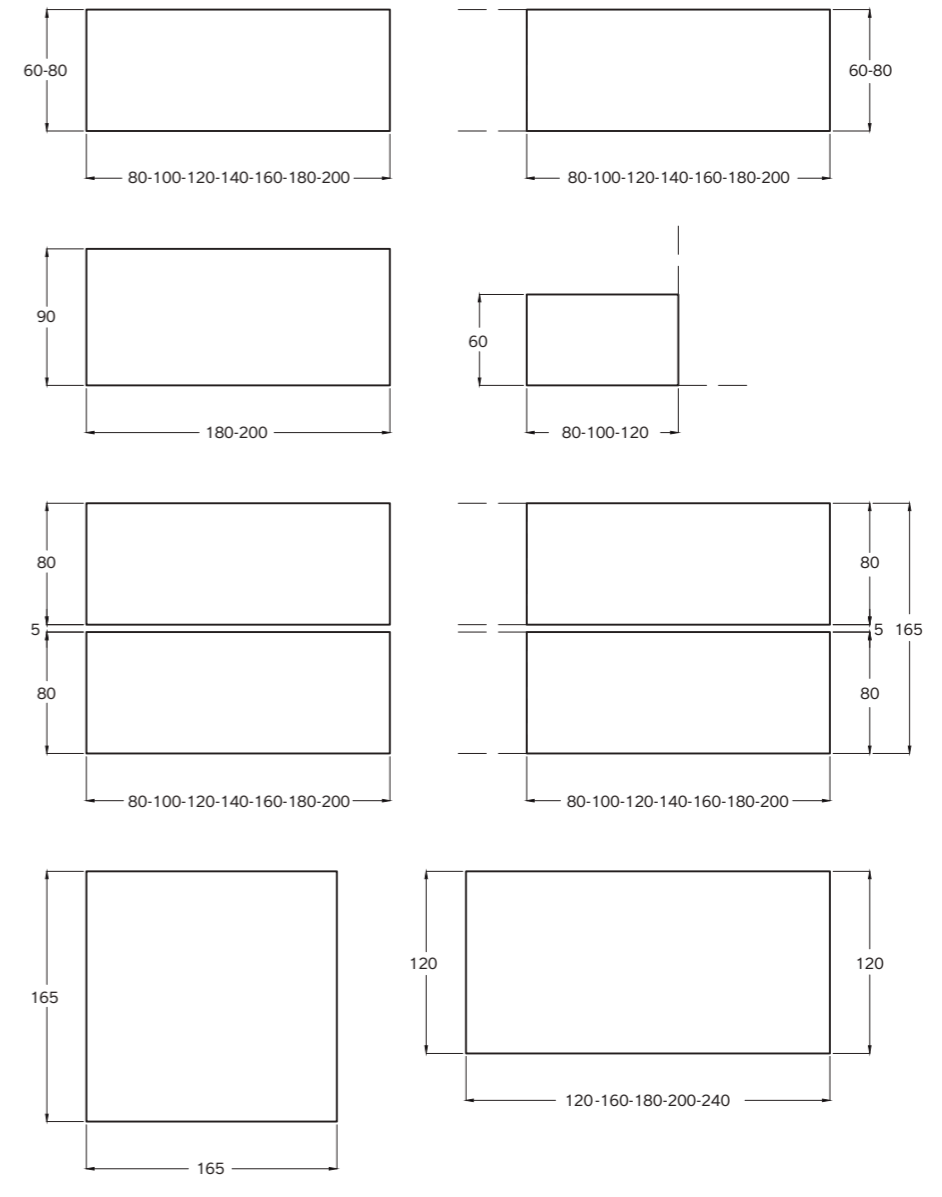
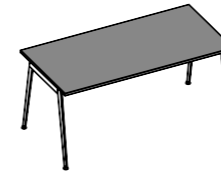

metallo | metal | metal

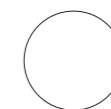

bianco
white
blanc



antracite
anthracite
anthracite



colori RAL
RAL colours
Couleurs RAL



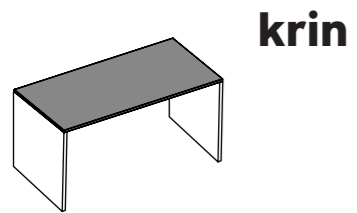

krin

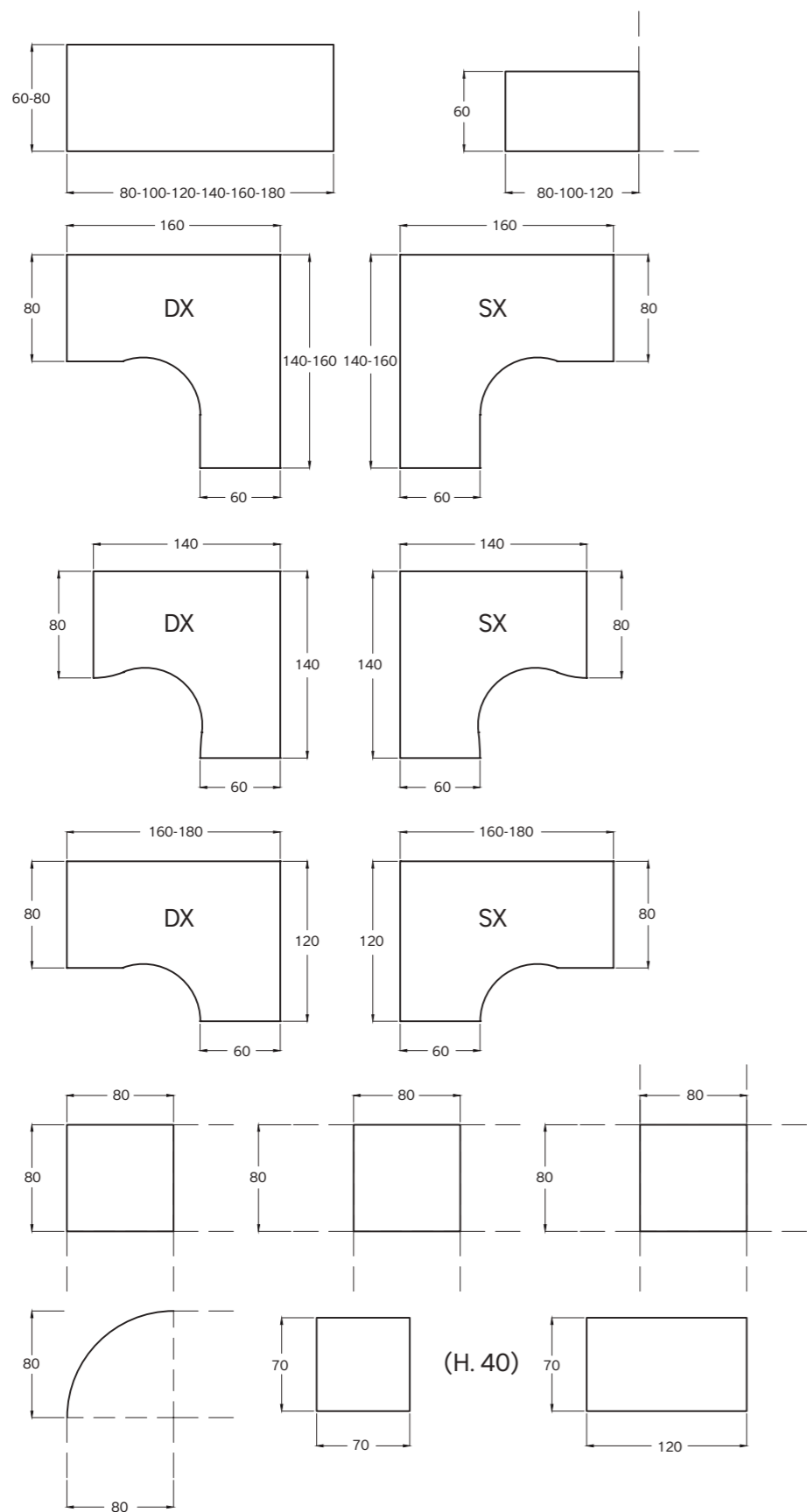

elementi di servizio

service elements
éléments de service

cassettiere su ruote

con maniglia

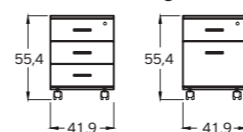

con presa laterale

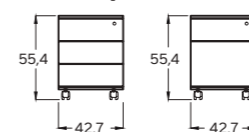

cassettiere portanti

con maniglia

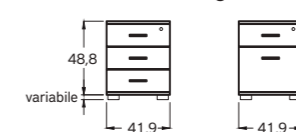

con presa laterale

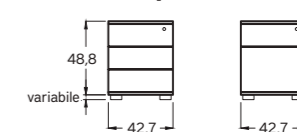

mobili di servizio su ruote

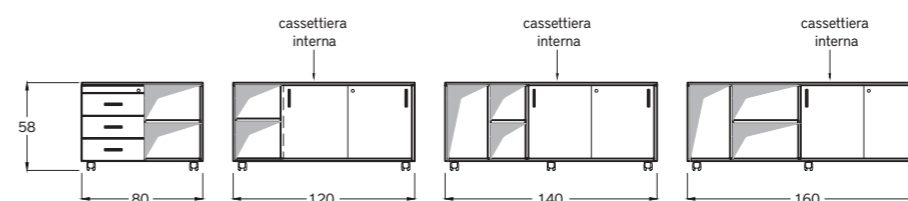

mobili di servizio portanti

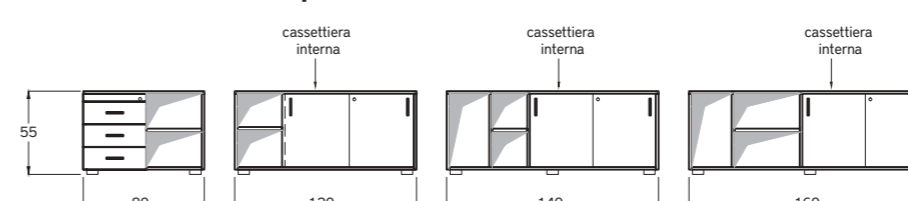

mobili Halite prof. 400mm completi di top

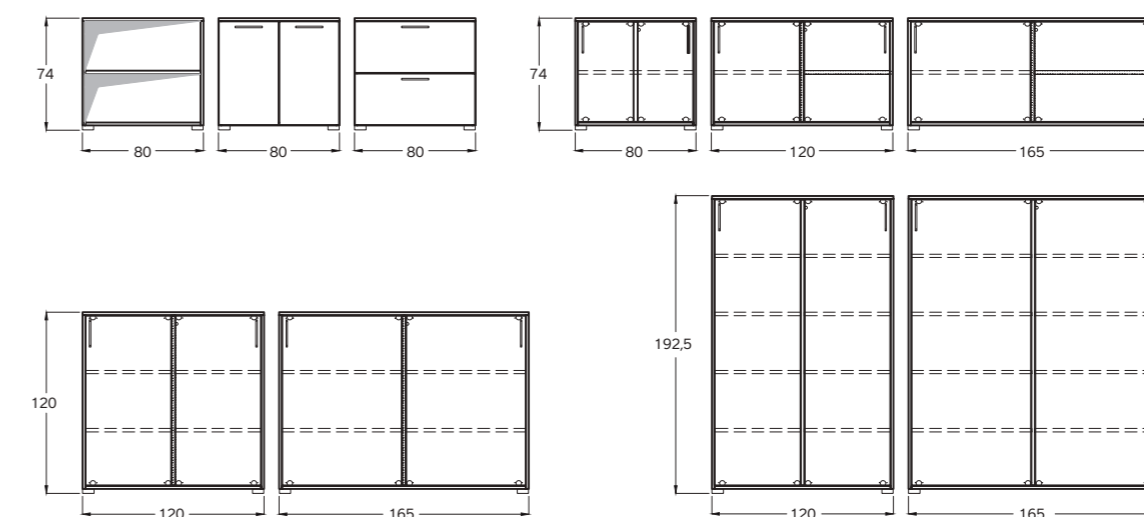

mobili Halite prof. 800mm con estraibile

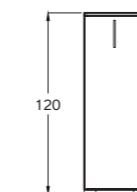

cubotto

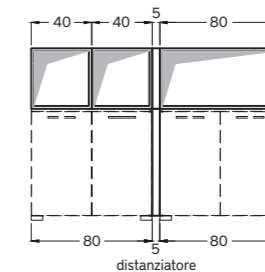

Mat

Materiali e finiture

Materials and finishes

Matériaux et finitions

METALLO / METAL / METAL



BIANCO

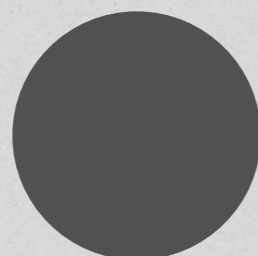

ANTRACITE



COLORI RAL

Decorativi

DECORATIVI LEGNO / WOOD / BOIS



113 | NOCE GRIGIO

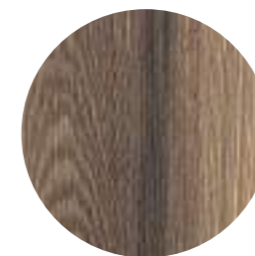

114 | ROVERE JAZZ

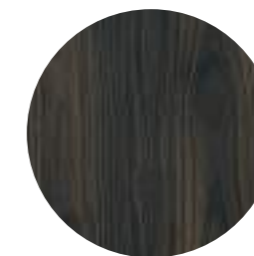

109 | OKOBO MINATO



109 | ROVERE MARGO

DECORATIVI COLORE / COLOR / COULEUR



MBI | BIANCO

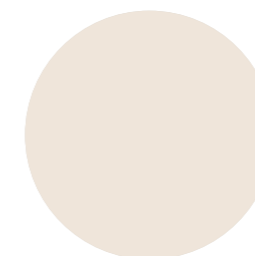

MMP | MADREPERLA

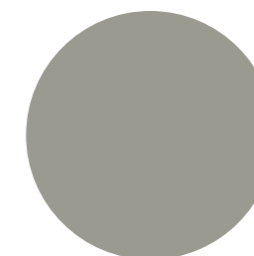

K14 | SABBIA

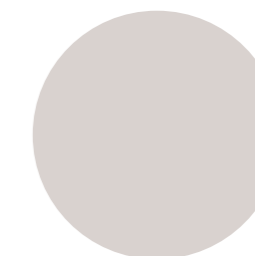

K15 | PLATINO

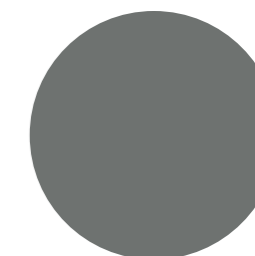

K17 | GRAFITE

DECORATIVI GAMMA LACCATA / LACQUERED / LACQUÉE



010 | CAOLINO



014 | GOBI

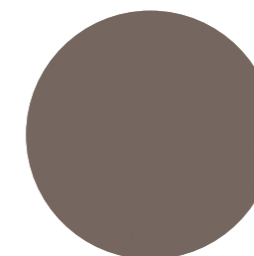

015 | VISONE

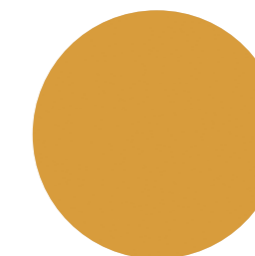

037 | CURRY

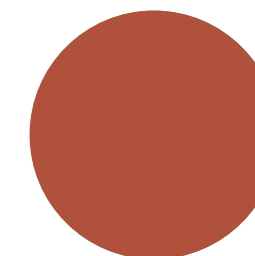

038 | PAPRIKA

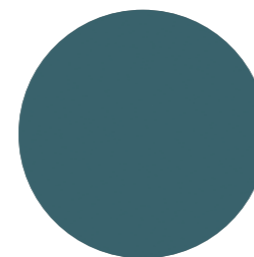

039 | INDIGO

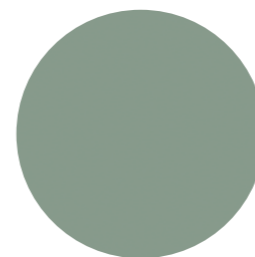

040 | KAFFIR



3096 | BIANCO

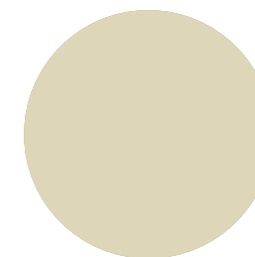

3104 | CORDA

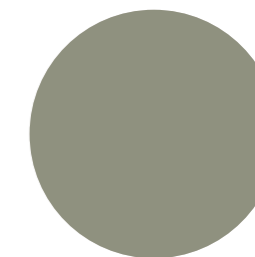

3151 | TORTORA

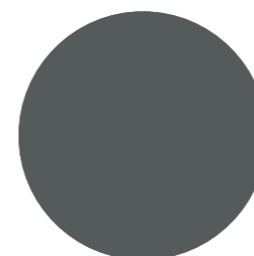

3155 | ANTRACITE

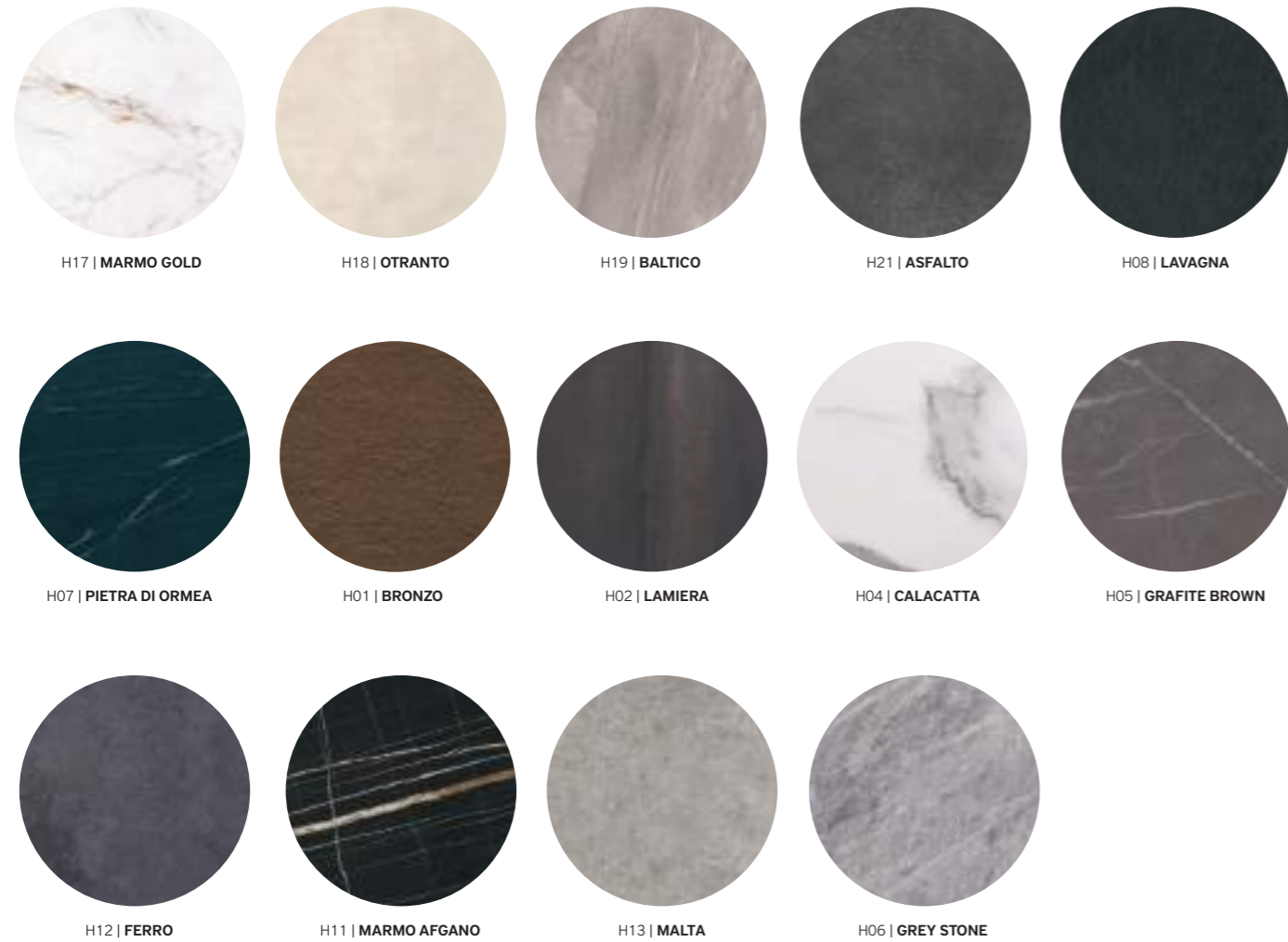

Pannelli costituiti da strati di materiale di fibra cellulosa impregnati di resine termoidurenti.

HPL è un laminato stratificato creato per azzerare i danni causati dall'acqua, dal vapore e dalle infiltrazioni degli oli, permettendo di evitare giunzioni e con la possibilità di dimensioni e forme finora non consentite da altri materiali.

HPL stratified laminated panels are made of layers of cellulose fibre materials which are impregnated with thermosetting resins.

This kind of stratified laminate is created in order to eliminate the damages caused by water, steam and oil infiltrations. This material allows the avoidance of joints and the possibility to have sizes and shapes, which were not possible in the past and with other materials.

Panneaux constitués de couches de fibres de celluloses imprégnées de résines thermodurcissables.

HPL est un stratifié en couches créé pour éliminer les dommages causés par les infiltrations d'eau, de vapeur et d'huile, permettant d'éviter les joints, avec la possibilité de proposer dimensions et de formes non autorisées auparavant par d'autres matériaux.

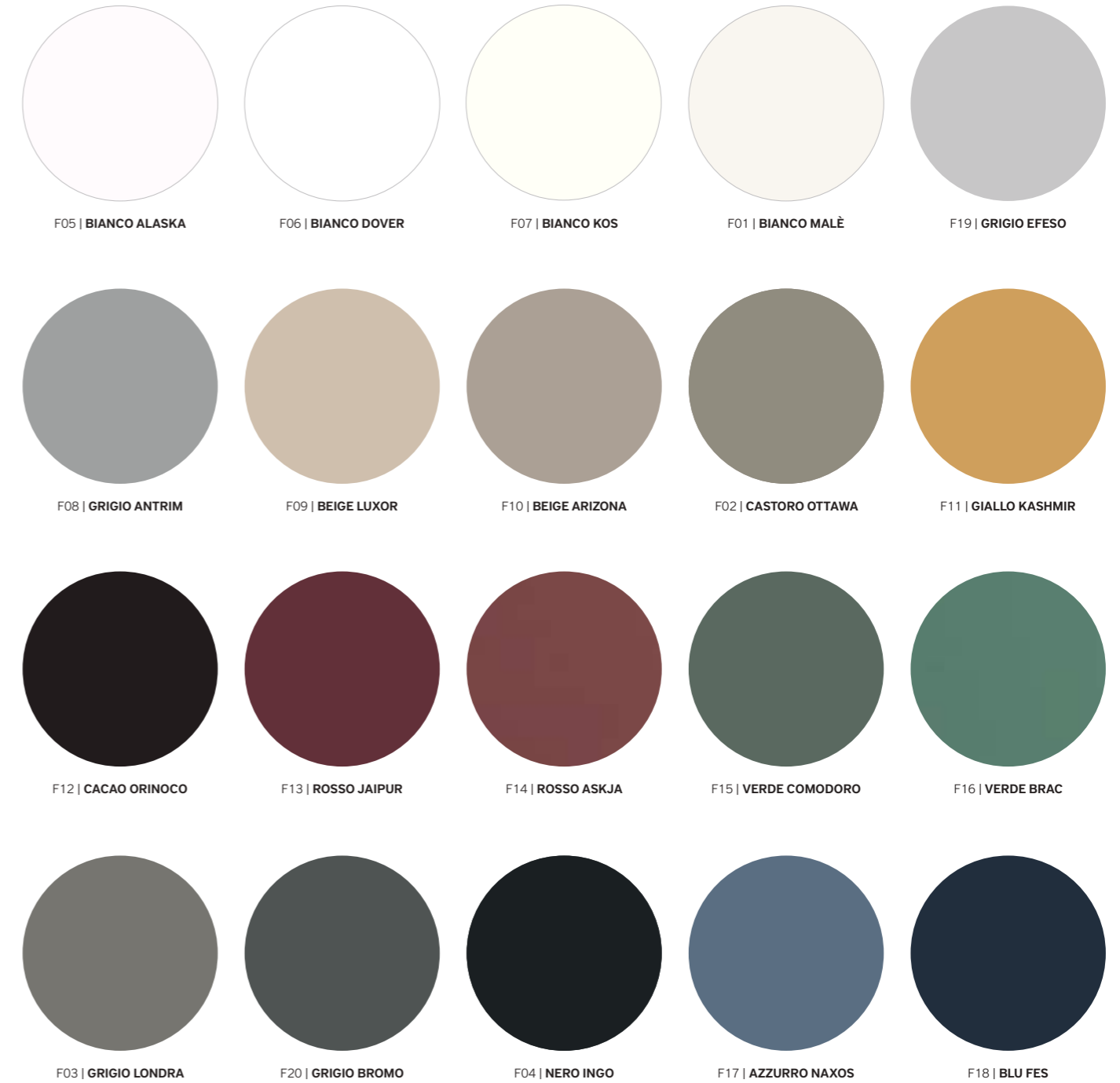

FENIX NTM® è un materiale innovativo creato per l'interior design, adatto ad applicazioni sia verticali sia orizzontali.

Con una bassa riflessione della luce, la sua superficie è estremamente opaca, anti impronte digitali e piacevolmente soft touch. Igienico, idoneo al contatto con gli alimenti, facile da pulire, antimuffa e idrorepellente: ecco le caratteristiche che lo rendono particolarmente adatto all'ambiente cucina.

FENIX NTM® is an innovative material created for interior design and suitable for both vertical and horizontal applications.

With low light reflectivity, the surface is extremely opaque, anti-fingerprint and pleasantly soft to the touch. Hygienic, suitable for contact with food, easy to clean, anti-mould and water-repellent: these are the characteristics that make it particularly suitable for the kitchen environment.

FENIX NTM® est un matériau innovant créé pour la décoration intérieure, adapté aux applications verticales et horizontales.

Avec sa faible réflexion lumineuse, sa surface est extrêmement opaque, anti-traces de doigts et est agréablement douce au toucher. Hygienne, adapté au contact avec les aliments, facile à nettoyer, anti-moisissure et hydrofuge: ces caractéristiques rendent ce matériau particulièrement adapté à l'environnement de la cuisine.

Mobil Office Furniture si riserva la facoltà di apportare al prodotto eventuali modifiche tecniche, dimensionali ed estetiche in qualsiasi momento senza preavviso.

Mobil Office Furniture reserves the right to make any changes to the product technical, dimensional and aesthetic at any time without notice.

Mobil Office Furniture se réserve le droit d'apporter au produit toute modification technique, dimensionnelle et esthétique, à tout moment et sans préavis.

A.D., graphic design, images: www.performaitalia.it
Colour separation: ImageVR
Print: Sinchromia

MOBILofficefurniture

Via Tittoni, 1 - 31020 Vidor (TV) - ITALY
Tel. +39 0423 988990 - Fax. + 39 0423 988870
mobilofficefurniture.it - info@mobilofficefurniture.it



think office



info@mobilofficefurniture.it



issuu